



OdiLite™

Made In U.S.A.

Professional Outdoor Image Projector



This weather-resistant projector beams the design you've selected onto a wall or garage door. Set into the ground at about 17 feet away from the projection surface, it creates a sharp, bright image 5 feet across. Enlarge or reduce the image by changing the projector's distance from the projected surface. A jack-o-lantern, bouquet of birthday balloons, holiday season greetings, and American flag are among the 21 foil image patterns you'll receive, and 1000 more can be special ordered. Anodized aluminum housing remains rust-free. Includes low-voltage 50 watt lamp and 9 inch ground stake. Weight: 6 lbs, Height: 20" high overall.



OdiLite kit includes:
 21 b&w foil images,
 4 full color images,
 3 color filters to add vibrant color to any b&w image,
 heat shield and stake,
 color image catalog,

Conceal the OdiLite with the RazRock.



RAZTECH Established 1983
 Manufacturing
 Engineering
 Office: 3549 East Reichert Drive, Crete, Illinois 60417
 Phone: (708)672-0808, Fax: (708)672-4323
 Factory / Repair Dept: 990 Richard Rd, Dyer, IN 46311
 Phone: (219)322-8800, Fax: (219)322-8831
 E-Mail: RazLight@AOL.COM
 Web: RazLight.com

Lighting

ODiLite™ Specifications

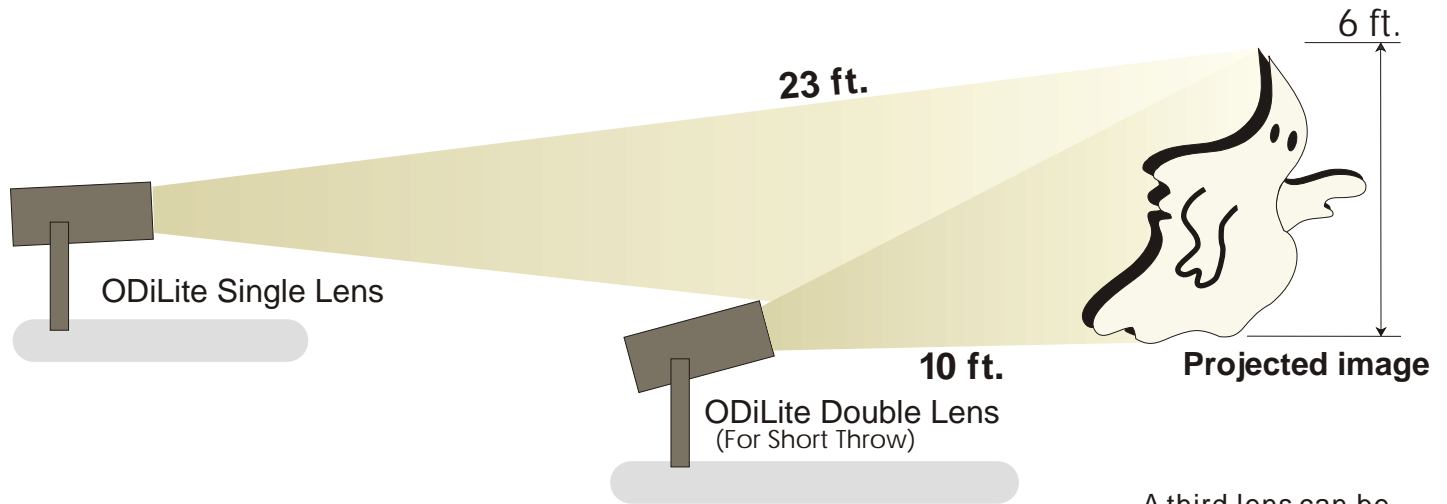

Variable beam spreads can be accomplished by repositioning lens, only on OdiLite double lens.

A third lens can be added to ODiLite for greater beam spread.

Lamp: 12volt RAZ1250N
Wattage: 50 Watts max.
Lamp Life: 3500 Hours

9.5"

14"

Built-in Transformer

Lock Knob

6 ft. Power Cord

120vac input

1" x 12" long Stake

Portable ODiLite

Item#	Description
ODi/s/r	Single Lens ODiLite for 23 foot throw
ODi/d/r	Double Lens ODiLite for 10 foot throw

Remote Transformer

6 ft. Power Cord

12vac power cable

120vac input

Underg round low voltage cabling

Permanent ODiLite

Item#	Description
ODi/s/r	Single Lens ODiLite for 23 foot throw
ODi/d/r	Double Lens ODiLite for 10 foot throw
Rem/75	Remote transformer 75watt(powers 1 ODiLite)
Rem/150	Remote transformer 150watt(powers 2 ODiLites)
Rem/225	Remote transformer 225watt(powers 3 ODiLites)
Rem/300	Remote transformer 300watt(powers 4 ODiLites)
Cab/15	15 feet of low voltage cable
Cab/30	30 feet of low voltage cable
Cab/50	50 feet of low voltage cable

Formula for image size and projector distance

d=distance from projected surface to Odilite (feet) i=image size (feet)	
Single lens formula	Double lens formula
d=3.80i i=0.26d	d=1.60i i=0.60d

Office: 3549 East Reichert Drive, Crete, Illinois 60417
Phone: (708)672-0808, Fax: (708)672-4323
Factory / Repair Dept: 990 Richard Rd, Dyer, IN 46311
Phone: (219)322-8800, Fax: (219)322-8831
E-Mail: RazLight@AOL.COM
Web: RazLight.com

Lighting

ODiLite™ Quick Instructions

Detailed instructions included within Image catalog

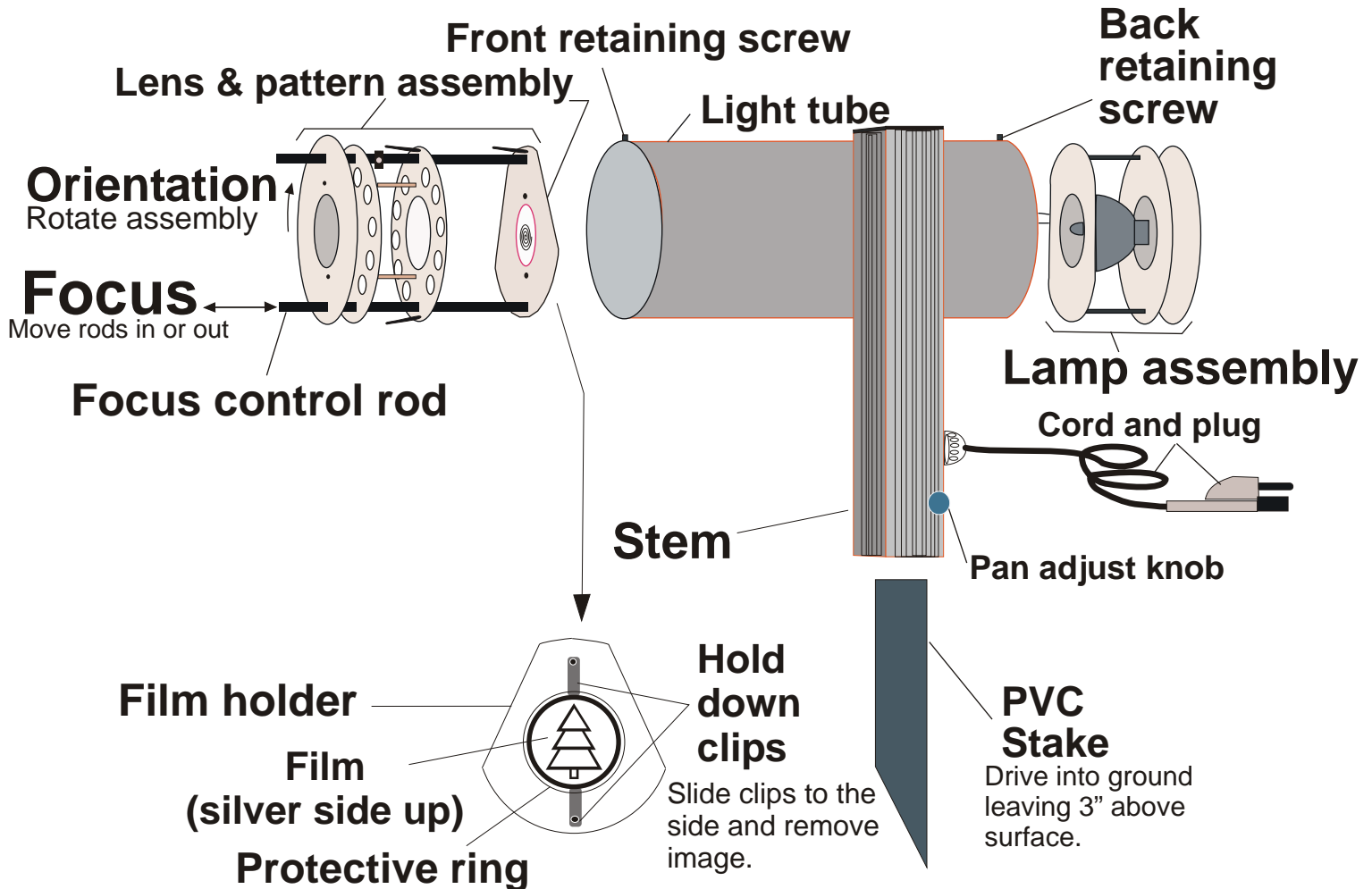

- 1.) Remove light fixture from box and swivel light tube about stem.
- 2.) Plug cord into receptacle.
- 3.) To Focus image move control rods in or out.
- 4.) Orientate image by rotating lens assembly within light tube.

Detailed instructions included
Within Image catalog.



Office: 3549 East Reichert Drive, Crete, Illinois 60417
 Phone: (708)672-0808, Fax: (708)672-4323
 Factory / Repair Dept: 990 Richard Rd, Dyer, IN 46311
 Phone: (219)322-8800, Fax: (219)322-8831
 E-Mail: RazLight@AOL.COM
 Web: RazLight.com

Lighting

UV/HEAT Blocking Filter

No assembly required

The UV filter kit is designed to reduce the damaging effects of heat and ultra-violet radiation emitted from the halogen lamp. By blocking the heat and ultra-violet light, the color film life is increased.

Instructions:

- 1.) Remove front retaining screw.
- 2.) Remove front lens assembly.
- 3.) Slide filter assembly in light tube until the 1st filter ring slides up against the Swivel nut. Make sure that the notch in the 2nd filter ring goes past the stem swivel nut. The final position of the filter assembly is as shown below.

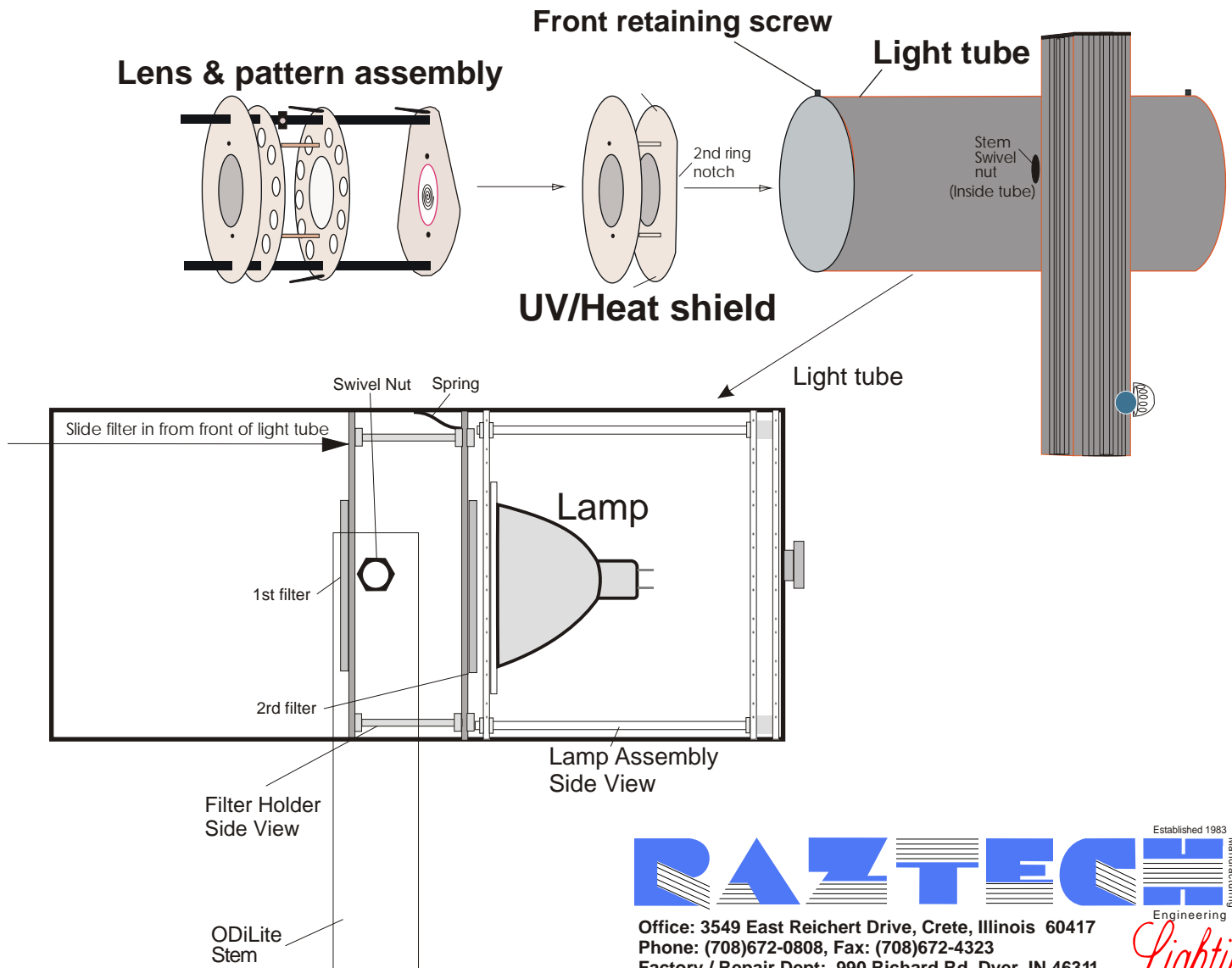

RAZTECH Established 1983
Manufacturing
Engineering

Office: 3549 East Reichert Drive, Crete, Illinois 60417
Phone: (708)672-0808, Fax: (708)672-4323
Factory / Repair Dept: 990 Richard Rd, Dyer, IN 46311
Phone: (219)322-8800, Fax: (219)322-8831
E-Mail: RazLight@AOL.COM
Web: RazLight.com

Lighting

Lamp Changing Instructions

****** Unplug and let lamp cool down before lamp changing ******

Loosen back retaining screw and slowly pull lamp assembly half way out. Unplug lamp socket and remove lamp from light tube. Loosen both retaining nuts and remove lamp. Plug in new lamp(RAZ1250N) and reverse disassembly process. **Be careful not to bend lamp pins or touch lamp inner reflector or bulb.** Also check and tuck lamp socket wires away from light beam.

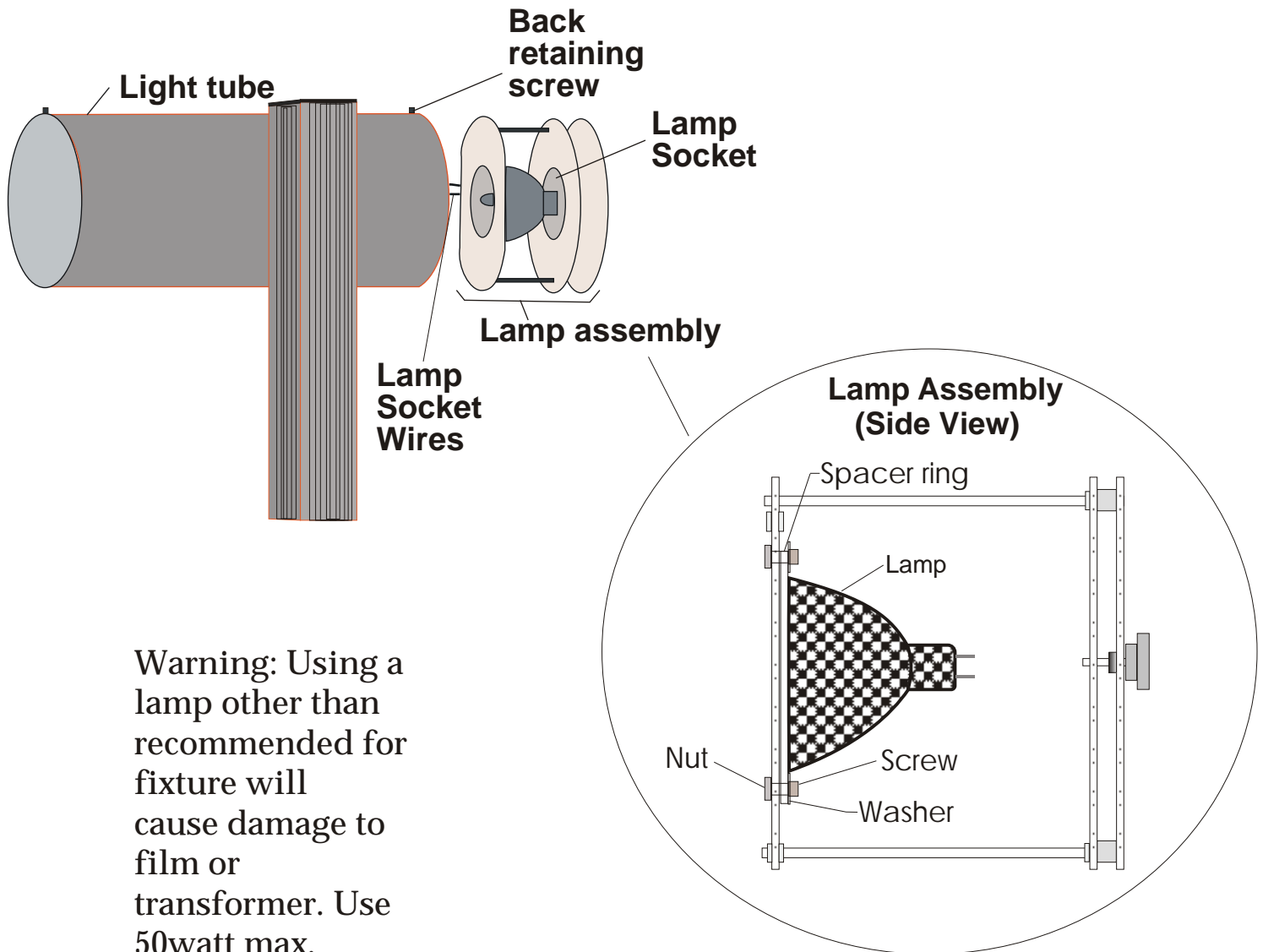

Warning: Using a lamp other than recommended for fixture will cause damage to film or transformer. Use 50watt max. Halogen lamp specified and sold by RazTech Lighting.



Office: 3549 East Reichert Drive, Crete, Illinois 60417
Phone: (708)672-0808, Fax: (708)672-4323
Factory / Repair Dept: 990 Richard Rd, Dyer, IN 46311
Phone: (219)322-8800, Fax: (219)322-8831
E-Mail: RazLight@AOL.COM
Web: RazLight.com

Lighting

Tamper Resistance Kit

The tamper resistance kit consists of two special keys and two sets of tamper resistant screws. The front and back retaining screws are replaced with #6 machine screws and, the stem is fastened to the PVC or 1" pipe with two #8 pointed tamper resistant screws.

- 1.) Determine OdiLite position for desired location and image size by trial and repositioning, or by using formulas provided in specifications.
- 2.) **Before staking pvc tube or any other tube stake , check ground for all electrical, gas, plumbing, or phone line hazards.**
- 3.) Stake PVC pipe(or longer 1 5/16" o.d. pipe) into ground with 3" left above ground, use a wood block on the end of the stake to prevent damage to the stake end.
- 4.) Pre-drill two holes(#29 drill bit) on each side of stem tube just below the pan adjusting knob. Slide ODiLite stem tube into PVC tube. Plug light cord into nearby receptacle. Position projected image by moving light tube(tilt) and, rotation about PVC tube, tighten pan adjust knob when finished positioning. Unplug light and finish drilling through the stem and tube with a #29 drill bit. Fasten the stem to the tube with the #8 pointed tamper resistant screw using the special key.

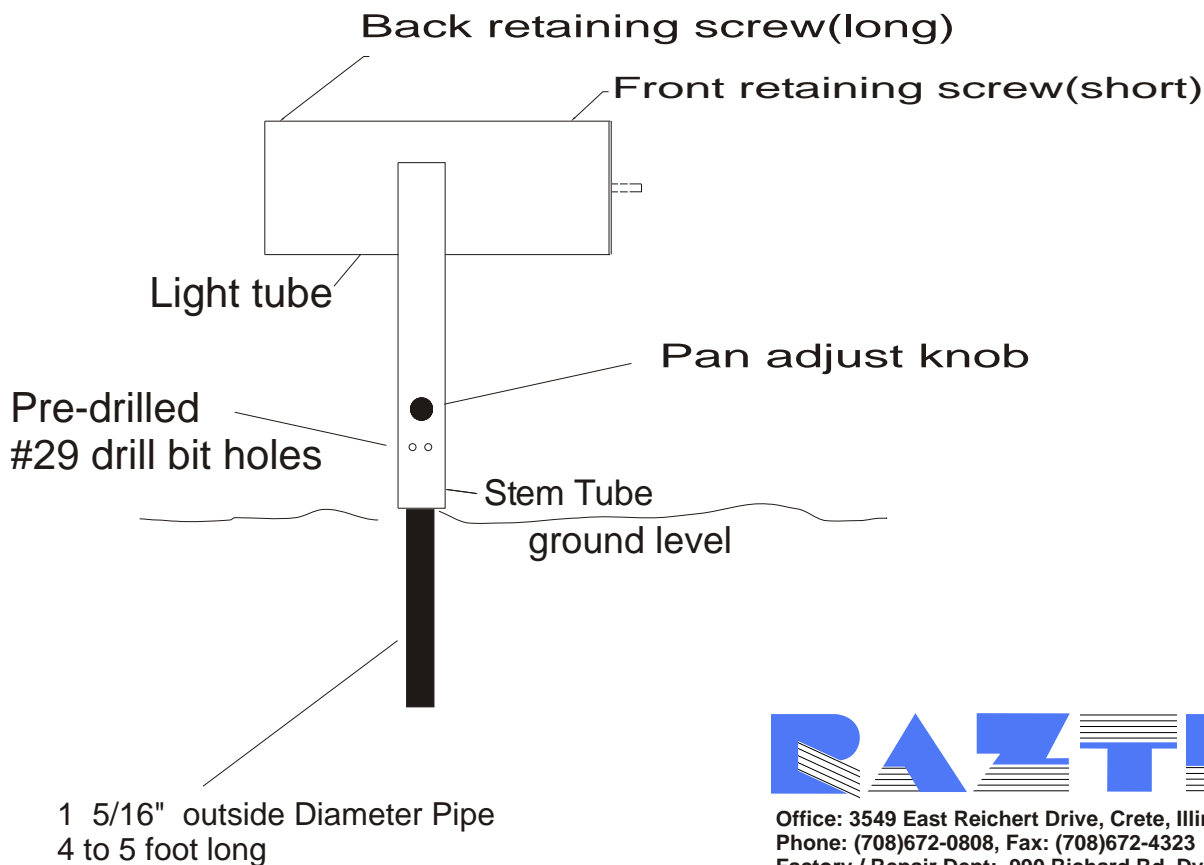

Office: 3549 East Reichert Drive, Crete, Illinois 60417
Phone: (708)672-0808, Fax: (708)672-4323
Factory / Repair Dept: 990 Richard Rd, Dyer, IN 46311
Phone: (219)322-8800, Fax: (219)322-8831
E-Mail: RazLight@AOL.COM
Web: RazLight.com

Lighting

ODiLite™

Mounting Instructions

The OdiLite projector can be mounted with standard 1" plumbing pipe. A sheet metal screw should be used to pin the OdiLite stem to the 1" pipe as shown in the examples below.

Ceiling Mount

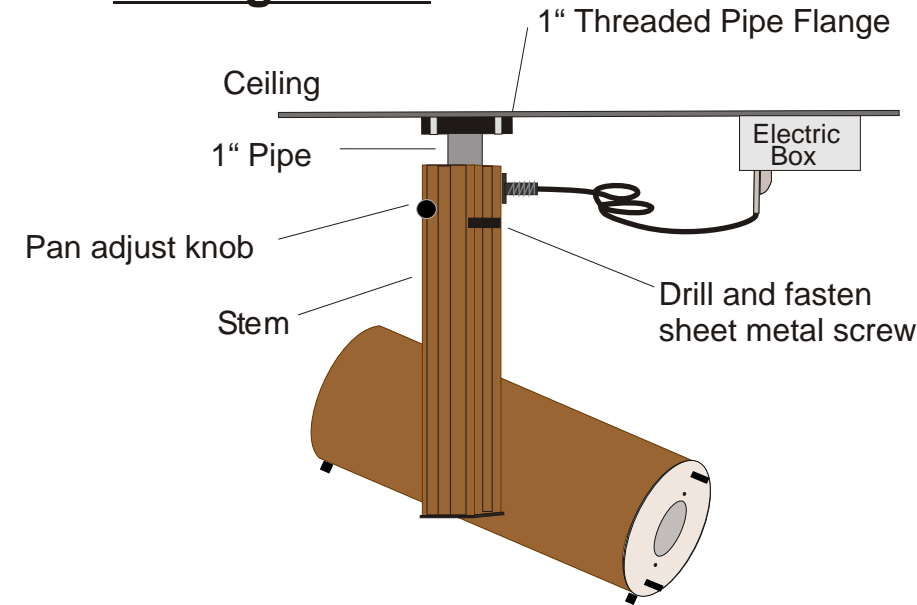

Wall mount

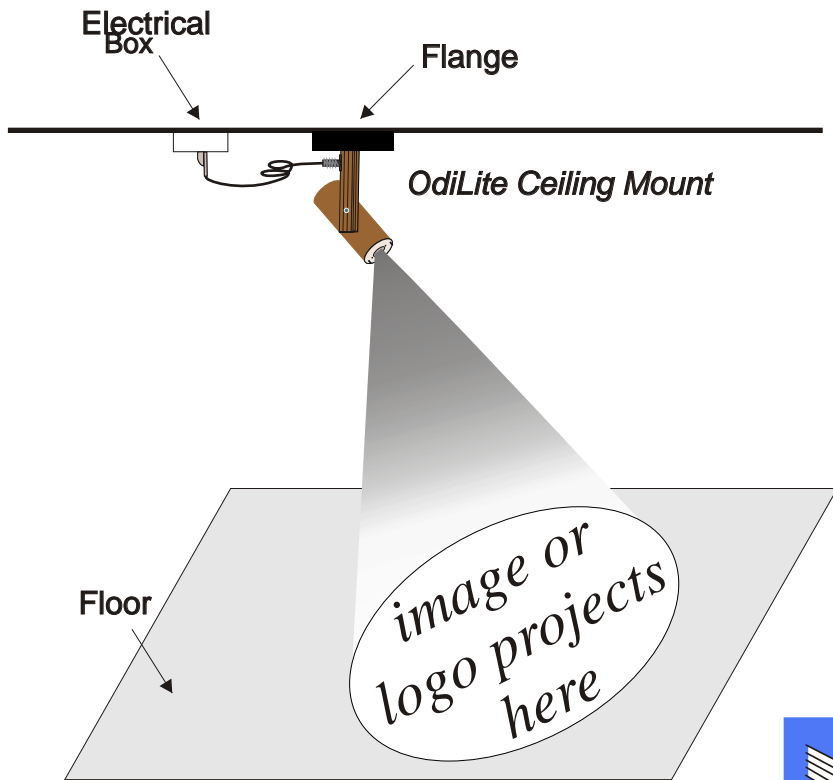
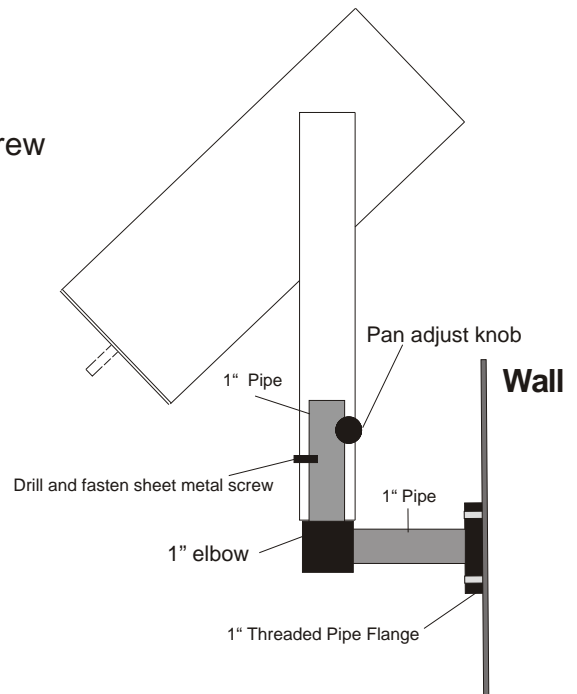

Office: 3549 East Reichert Drive, Crete, Illinois 60417
Phone: (708)672-0808, Fax: (708)672-4323
Factory: 990 Richard Road, Dyer, Indiana 46311
Phone: (219)322-8800, Fax: (219)322-8831
E-Mail: RazLight@AOL.COM
Web: RazLight.com

Lighting